

VA Flow Meters RA 65/FA 65

Design and applications

Measuring units RA 65 and FA 65 are based on the variable area float principle.

In pipelines the RA 65 is installed by means of screwed pipe joints and the FA 65 is mounted between flanges. The borosilicate glass measuring cone is located inside a protective steel tube with an inspection window.

VA flow meters RA 65 and FA 65 are most suitable for the flow measurement of transparent fluids, and gases. Each unit is customized with a scale specific for the medium to be measured. RA 65 and FA 65 are used in plant engineering (e.g. furnace construction and water treatment).

By installation of electrical limit switches, which are adjustable throughout the entire measuring range, these units can be employed as detectors too.



- calibrated borosilicate measuring glass
- armature with protective steel tube
- reliable
- due to simple mode of operation
- with limit switches usable as detectors
- scales specific for the media to be measured
- C€ 0085BN0045

VA Flow Meters

RA 65/FA 65

Technical data

Nominal pressure rating	RA 65: PN 10 at 20 °C FA 65: PN 10 at 20 °C
max. operating pressure	see table of measur. ranges on page 3
Temperature resistance	80 °C at 5 bar overpressure
Measuring range	1:10
Accuracy class	1,6 acc. to VDI/VDE 3513
Connection RA 65	Two-part pipe fitting: Insert with cylindrical female thread acc. to ISO 7-1
Connection FA 65	Flange PN 10 acc. to DIN 2501, other connections on request

Materials

Protective tube	Precision steel tube of steel St. 35
Heads RA 65	Grey cast iron, size 9.5 steel
Fitting	Malleable cast iron, galvanized
Flanges FA 65	Grey cast iron, size 9.5 steel
Measuring cone	Borosilicate glass
Seals	Standard NBR optionally Viton, EPDM, silicone
Float for fluids ¹⁾	Standard: 1.4305 optionally: 1.4571, PVC, PP, PVDF or PTFE with lead core
Float for gases ¹⁾	Standard: Aluminium optionally: PVC, PP, PTFE, PVDF or 1.4571
float for limit switches ¹⁾	Standard: 1.4571 with magnetic core or PVC with magnetic core

¹⁾ With small sizes VA flow meters floats unguided, from size 30 B partly with guide rod. We will send you a detailed table on request.

Dimensions

Size	Pipe fitting	RA 65			
		S	L	d ¹⁾	H
9.5	Rp 1/4	28	308	12	25
	Rp 3/8	32	310	16	
	Rp 1/2	39	312	20	
19	Rp 1/2	39	413	20	45
	Rp 3/4	48	420	25	
	Rp 1	55	424	32	
30	Rp 1	55	424	32	60
	Rp 1 1/4	67	428	40	
	Rp 1 1/2	74	430	50	
36	Rp 1 1/4	67	428	40	70
	Rp 1 1/2	74	430	50	
	Rp 2	90	445	63	
43	Rp 1 1/2	74	430	50	90
	Rp 2	90	445	63	
	Rp 2 1/2	111	446	75	
	Rp 3	131	450	90	

¹⁾ d with gluing or welding sleeves

Size	FA 65								
	DN	L	H	D	d ₄	k	Screws Qty.	Thread	d ₂
9.5	10	260	25	90	40	60	4	M 12	14
	15			95	45	65	4	M 12	14
19	15	360	45	95	45	65	4	M 12	14
	20			105	58	75	4	M 12	14
	25			115	68	85	4	M 12	14
30	20	360	60	105	58	75	4	M 12	M 12
	25			115	68	85	4	M 12	14
	40			150	88	110	4	M 16	18
36	25	360	70	115	68	85	4	M 12	M 12
	40			150	88	110	4	M 16	18
	50			165	102	125	4	M 16	18
43	50	360	90	165	102	125	4	M 16	18
	65			185	122	145	4	M 16	18

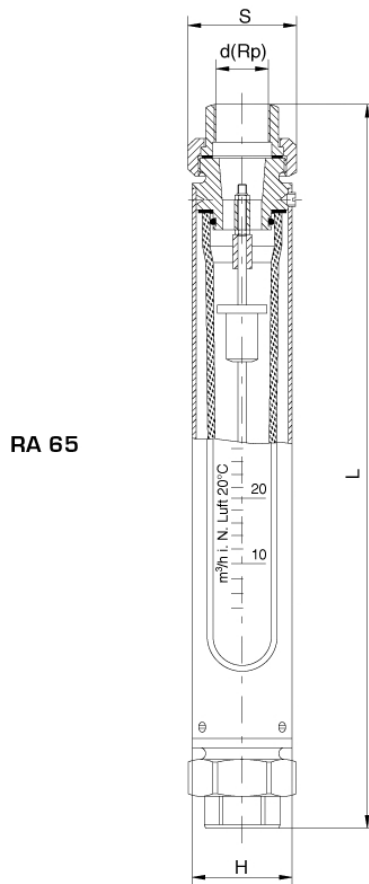

RA 65

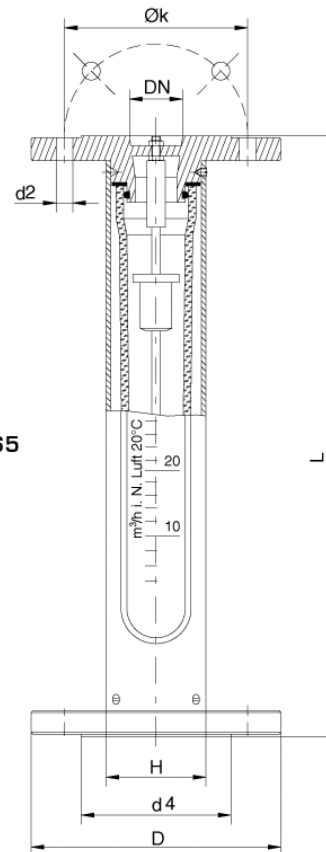

FA 65

Measuring ranges (min. and max. measuring range; all intermediate measuring ranges are possible)

Size	Measuring range m ³ /h H ₂ O	Measuring range m ³ /h at s.c. air ¹⁾	RA 65 pipe fitting	Connections RA 65 gluing or welding sleeves	FA 65 Flange connection DN	max. oper. pressure in bar bei 20 °C
9.5	0.5 - 5 l/h 20 - 200 l/h	0.006 - 0.06 0.3 - 3.3	Rp 1/4 Rp 1/4 Rp 1/2	d 12 d 16 d 20	10 15	10
19	0.012 - 0.12 0.12 - 1.2	0.15 - 1.5 1.6 - 16	Rp 1/2 Rp 3/4 Rp 1	d 20 d 25 d 32	10 15 20 25	10
30	0.1 - 1 0.3 - 3	1.3 - 13 3.6 - 36	Rp 1 Rp 1 1/4 Rp 1 1/2	d 32 d 40 d 50	25 40	10
36	0.4 - 4 0.8 - 8	4 - 40 8 - 80	Rp 1 1/4 Rp 1 1/2 Rp 2	d 40 d 50 d 63	40 50	8
43	0.9 - 9 1.6 - 16	5 - 50 16 - 160	Rp 1 1/2 Rp 2 Rp 2 1/2 Rp 3	d 50 d 63 d 75 d 90	50 65	8

Measuring ranges for other measuring substances and operating conditions on request.

¹⁾ at s.c.: at standard conditions (0 °C and 1.013 bar abs.)



VA Flow Meters

RA 65/FA 65

**Limit switches
MSK 1/MSK 12**

In order to realize a local display with a monitoring function the flowmeter can be equipped with limit switches. The limit switch consists of a bistable reed contact switched by the magnet integrated in the float. The switch is guided in a guide slot on the back of the protective tube and can be adjusted throughout the entire measuring range. In case of inductive or capacitive load applications, e.g. caused by contactors or solenoid valves, uncontrolled current and voltage peaks may occur. In dependence on their geometry such peaks also occur in lines, if they exceed a certain length. It is therefore recommended to use an additionally available arc suppression relay "MSR". This increases the switching capacity and avoids the appearance of inductive and capacitive peaks. It thereby ensures a long lifetime of the contact.

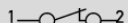
**Technical data of the
limit switches**

Design	MSK 1	MSK 12
Switching voltage	230 V AC/DC	230 V AC/DC
Switched current	0.5 A	0.5 A
Switching capacity	10 W/VA	10 W/VA
Dielectric strength	400 V	400 V
Temperature range	- 40 to + 50 °C	- 40 to + 50 °C
	the temperature resistance of the flow meter is decisive	
Switching function	Normally closed contact 	Normally open contact 

Notes on safety

For safety reasons we recommend to use the VA flow meters with glass measuring tubes only in combination with a protective shield in front of the measuring tube.

Avoid extreme pressure shocks.

The equipment from KIRCHNER has been tested in compliance with applicable CE-regulations of the European Community.

The respective declaration of conformity is available on request.

The KIRCHNER QM-System is certified in accordance with DIN-EN-ISO 9001:2000. The quality is systematically adapted to the continuously increasing demands.

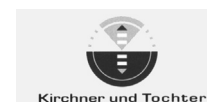

Variable area flow meters

SGM

Design and application

In all cases where a dependable device is required for indicating instantaneous values and monitoring the flow in pipelines, the SGM is the obvious choice as a reliable device for measuring the flow of liquids and gases. Since the vertical position of the float is transmitted magnetically to a dial gauge, the SGM, as opposed to standard type variable area flow meters with a glass tube, is also suitable for measuring the flow of opaque media. Each device is individually calibrated to meet customer specifics and fitted with a medium specific scale.

For process control, the flow meter can be equipped with a limit switch and/or measuring transmitter with electrical analog output.



- All-metal device, indication via magnetic coupling
- High resistance to pressure and temperature
- DN 15 to DN 100
- Low pressure loss
- Limit switch
- Analog output 4-20 mA
- Optionally available in explosion-protected design
- On request with PTFE liner
- CE 0085BN0048
- Optionally available for horizontal installation

**Variable area flow
meters**
SGM
Series

Version	Description
SGM	All-metal device
SGM-EM	with electrical signal output
SGM-EMZ	with electrical signal output and totalizer
SGM-IK1	with one inductive switch (SC3,5-N0-Y)
SGM-IK2	with two inductive switches (SC3,5-N0-Y)
SGM-IKS1	with one electronic switch (SB3,5-E2)
SGM-IKS2	with two electronic switches (SB3,5-E2)
SGM-IK1-EM	with one inductive switch and with electrical signal output
SGM-IK1-EMZ	with one inductive switch and with electrical signal output and totalizer
SGM-IK2-EM	with two inductive switches and with electrical signal output
SGM-IK2-EMZ	with two inductive switches and with electrical signal output and totalizer
SGM-IKS1-EM	with one electronic switch and with electrical signal output
SGM-IKS1-EMZ	with one electronic switch and with electrical signal output and totalizer
SGM-IKS2-EM	with two electronic switches and with electrical signal output
SGM-IKS2-EMZ	with two electronic switches and with electrical signal output and totalizer
Optionally	Version/Description
SGM EEx	All-metal device, explosion-protected design
SGM-EM EEx	with electrical signal output, explosion-protected design
SGM-IK1 EEx	with one inductive switch, explosion-protected design
SGM-IK2 EEx	with two inductive switches, explosion-protected design
SGM-IK1-EM EEx	with one inductive switch and with electrical signal output, explosion-protected design
SGM-IK2-EM EEx	with two inductive switches and with electrical signal output, explosion-protected design

Materials

Version	Measuring tube/float	Temperature	Env.-
SGM / VA	st. steel/st. steel	- 80°C ... + 300°C	≤ 120°C
SGM / C ₄	Hastelloy C ₄ /Hastelloy C ₄	- 80°C ... + 300°C	≤ 120°C
SGM / PTFE	PTFE ¹⁾ /PTFE	70°C	≤ 70°C
SGM / PTFE / K	PTFE ¹⁾ /ceramic	150°C	≤ 70°C
SGM / TFM / K	TFM ¹⁾ /ceramic	250°C	≤ 120°C
Indicator part:			
Scale case	aluminium, painted		
Pointer	aluminium, painted		
Scale	aluminium, coated		
Pane	float glass		

¹⁾ Measuring tube of stainless steel (1.4404) with liner

Technical data

Accuracy class	
Standard (VA/C ₄)	1,6 to VDE/VDI 3513
alt. (PTFE/ceramics)	2,5 to VDE/VDI 3513
Indicator part	
Scale	in phy. units, e.g. l/h, m ³ /h
Scale length	90 mm
Turndown ratio	1:10
Degree of protection,	IP 67, NEMA 4X
indicator part	
Stainless steel version	
Allowable operating pressure	
DN 15, DN 25, DN 50	PN 40
DN 80, DN 100	PN 16
PTFE version	
Allowable working pressure	same as for stainless steel version
Connections	
Flanges to DIN 2501 (EN-1092-1), on request: ANSI B 16.5, JIS, DIN 11851, screw connection to ISO 228	

Options
Limit switch

Up to two inductive switches can be built into the indicator part.

The inductive contact switches (hysteresis-free) when the contact vane dips into the slot-type initiator. The setting pointer trips when the limit value is over- or undershot.

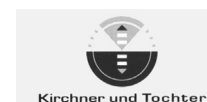

Switch types:

SC3,5-N0-Y	2-wire technology (NAMUR)
SB3,5-E2	3-wire technology (Non Ex)

2-wire SC3,5-N0-Y	
Switching element function	NAMUR NC contact
Nominal voltage U_0	8 V
Current consumption:	
Pointer vane not sensed	≥ 3 mA
Pointer vane sensed	≤ 1 mA
Ambient temperature	- 25°C to + 100°C
EMV according to	NE21
SIL according to	IEC 61508
Approval certificate	PTB 99 ATEX 2219X only with isolation switching amplifier
3-wire SB3,5-E2	
Switching element function	PNP NO contact
Nominal voltage U_0	10...30 V
Current consumption:	
Pointer vane not sensed	$\leq 0,3$ V
Pointer vane sensed	$U_b - 3$ V
Ambient temperature	- 25°C to + 70°C
Continuous current	max. 100 mA
No-load current I_0	≤ 15 mA
EMV according to	EN 60947-5-2

Degree of protection (EN 60529 / IEC 529) IP 67, NEMA 6

EM Electrical transmitter two-wire technology

The EM electrical signal output can be built into the indicator part.

A load-independent current of 4 to 20 mA in 2-wire connection is supplied that is proportional to the instantaneous flow rate. Provided it has an intrinsically safe power supply, the transmitter can also be used in hazardous areas.

Product data and measuring range are easily retrieved with the help of HART® communication.

Power supply	24 V DC
Current consumption	4 to 20,4 mA for 0% to 102,5% of the measured value
Namur failure signal	> 20,8 mA
Reproducibility	< 0,1% of FS
Linearity error	< 0,1%
Influence of supply power	< 0,1%
Ext. resistance dependence	< 0,1%
Temperature effect	< 5µA / K
Max. load impedance	0 (250) to 800 Ω
Individual certificate	PTB 00 ATEX 2063

* With HART® communication, this value is the minimum value

For use in hazardous areas: built-in equipment may only be connected to separate intrinsically safe circuits.

EMZ electrical transmitter with totalizer

The EMZ flow totalizer in 3-wire technology can be installed together with the EM electrical current output.

A 6-digit LED display indicates the total flow value and can be switched over to indicate the instantaneous flow rate in 0...100%.

A galvanically separated pulse output supplies a pulse on each totalizer advance indicated.

Data save is automatic in the event of voltage drop!

The EMZ flow counter is not suitable for use in hazardous areas!

If an indicator with totalizing function is required in the hazardous zone, this must be of special design - a digital display unit in flameproof enclosure "Ex d". The cable entry gland (to be provided by customer) must accordingly also be of flameproof design.

Supply power	16...30 V DC
Rest. current loop	0...600 Ω
Power consumption	max. 2 Watt
Power supply, pulse out	10...30 V DC
Max. current	50 mA
Max. power loss	250 mW
T on	fixed pulse width 80 ms
T off	dependent on flow rate
U on	$U_b - 3$ V
U off	0 V
Pulse value	1 puls = 1 flow unit (1 litre, 1 m³, ...)
Ambient temperature	- 25°C bis + 65°C
Indication error	< 1% of value indicated, max. one display unit

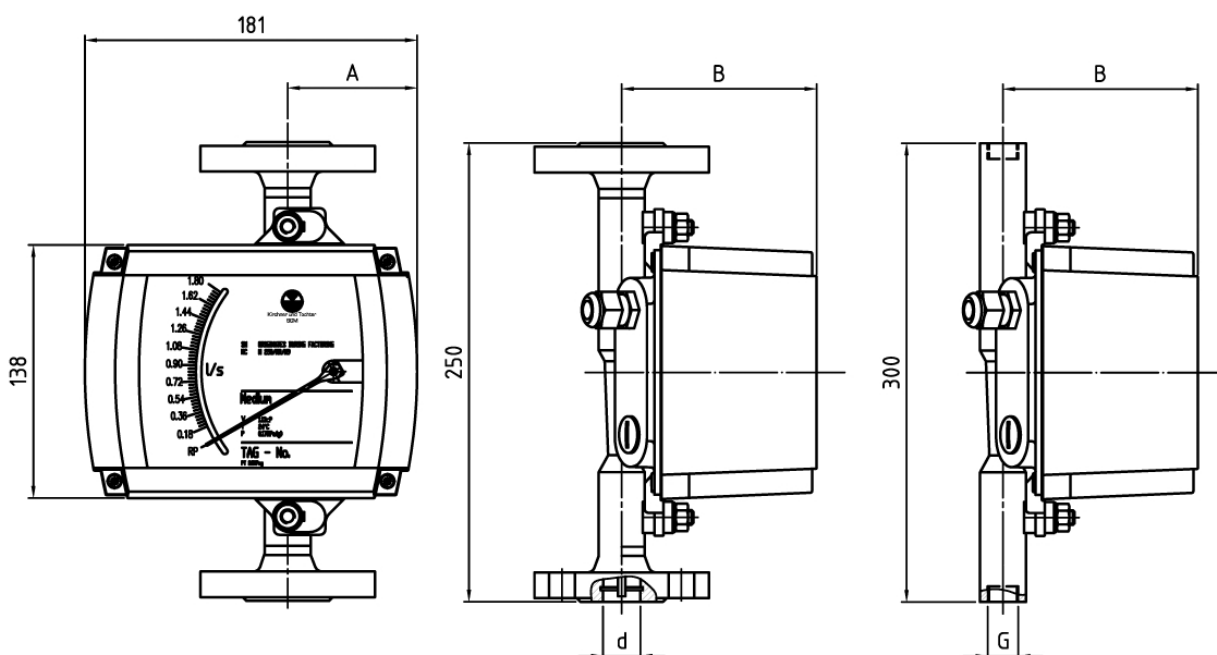

Dimensions and weights

(Design: stainless steel with flanged connection)

DN	PN	Dimensions			Ø d	Weight kgs	
		L	A	B		DIN flanges	with heating
15	40	250	70,5	107	20	3,5	4,8
25	40	250	70,5	119	32	5,0	6,7
50	40	250	57,5	132	65	8,2	10,4
80	16	250	57,5	148	89	12,2	14,0
100	16	250	57,5	158	114	14,0	16,6

Overall length for devices with internal thread to ISO 228: 300 mm, to ANSI B 16.5 (3" / 300 lbs and higher): 300 mm

(Design: ceramic/PTFE with flanged connection)

DN	PN	Dimensions			Ø d	Weight kgs	
		L	A	B		DIN flanges	
15	40	250	70,5	107	20	3,5	
25	40	250	70,5	119	32	5,0	
50	40	250	57,5	132	65	10,0	
80	16	250	57,5	148	89	13,0	
100 ¹⁾	16	250	57,5	158	114	15,0	

¹⁾ PTFE only

Overall length for devices with internal thread to ISO 228: 300 mm, to ANSI B 16.5 (3" / 300 lbs and higher): 300 mm

(Design: stainless steel with internal thread connection)

DN	G	Dimensions			Ø d	Weight kgs	
		L	A	B			
15	G 1/2	300	70,5	107	20	3,5	
15	1/2" NPT	300	70,5	107	20	3,5	
15	3/4" NPT	300	70,5	107	20	3,5	
15	G 1	300	70,5	107	20	3,5	
25	G 1	300	70,5	119	32	5,0	
25	1" NPT	300	70,5	119	32	5,0	

SGM Variable area flow meters

Measuring ranges (stainless steel design)

Size	Stainless steel float			
	Water l/h	Pressure loss mbar	Air m ³ /h at STP ¹⁾	Pressure loss mbar
15 or 1/2"	2,5 – 25	26	0,065 – 0,65	21
	4,0 – 40	26	0,1 – 1	21
	6,3 – 63	26	0,15 – 1,5	21
	10 – 100	26	0,22 – 2,2	21
	16 – 160	26	0,36 – 3,6	21
	25 – 250	26	0,55 – 5,5	21
	40 – 400	28	1,0 – 10	21
	63 – 630	32	1,4 – 14	22
	100 – 1000	50	1,8 – 18	38
25 or 1"	63 – 630	32	1,4 – 14	24
	100 – 1000	33	2,2 – 22	24
	160 – 1600	34	3,5 – 35	25
	250 – 2500	38	5,0 – 50	26
	400 – 4000	45	8,0 – 80	30
	630 – 6300	103 ²⁾	11,0 – 110	78
			17,0 – 170	103 ²⁾
50 or 2"	630 – 6300	74	8,0 – 80	13
	1000 – 10000	77	11,0 – 110	13
	1600 – 16000	84	15,0 – 150	13
	2500 – 25000	104	23,0 – 230	60
			35,0 – 350	69
		60,0 – 600	104	
80 or 3"	2500 – 25000	68	35,0 – 350	16
	4000 – 40000	89	40,0 – 400	16
100 or 4"	6300 – 63000	120		
	10000 – 100000	220		

Float damping system recommended for devices used for gas flow measurement!

¹⁾ at STP (0°C and 1.013 bar abs.)

²⁾ 300mbar with damping

Measuring ranges (PTFE/ceramic design)

Size	PTFE float		Ceramic float		Air m ³ /h at STP ¹⁾	Pressure loss mbar
	Water l/h	Pressure loss mbar	Water l/h	Pressure loss mbar		
15 or 1/2"	2,5 – 25	65	3 – 30	62		
	4,0 – 40	66	5 – 50	64	0,18 – 1,8	64
	6,3 – 63	66	7 – 70	66	0,24 – 2,4	66
	10 – 100	68	13 – 130	68	0,40 – 4,0	68
	16 – 160	72	20 – 200	70	0,65 – 6,5	70
	25 – 250	86	25 – 250	72	0,90 – 9,0	72
	40 – 400	111				
25 or 1"	63 – 630	70	50 – 500	55	1,8 – 18	55
	100 – 1000	80	70 – 700	60	2,2 – 22	60
	160 – 1600	108	110 – 1100	70	3,0 – 30	70
	250 – 2500	158	160 – 1600	82	5,0 – 50	82
			250 – 2500	100	7,5 – 75	100
50 or 2"	400 – 4000	81	450 – 4500	70	14 – 140	70
	630 – 6300	110	630 – 6300	80	20 – 200	80
	1000 – 10000	170	1100 – 11000	110	35 – 350	110
80 or 3"	1600 – 16000	81	1600 – 16000	70		
	2500 – 25000	95	2500 – 25000	85		
100 or 4"	4000 – 40000	100				

Float damping system recommended for devices used for gas flow measurement!

¹⁾ at STP (0°C and 1.013 bar abs.)

